

EESy Solutions

Engineering Equation Solver Newsletter

Inside this issue:

Welcome	1
<i>Thermodynamics</i>	1-2
EES Training opportunities	3
Macro command enhancements	4
Controlling Excel from EES	5
Controlling EES from MATLAB	6
Controlling EES from LabView	7
Foreign language capabilities	8
New fluid properties	8
Introduction to EES videos	8
Instant Update Service	8

Welcome

This is the 22nd issue of EESy Solutions, a newsletter that is developed to provide news, tips, and other updates to users of the Engineering Equation Solver software. EES has been a commercial software for more than two decades. If you have missed any of the previous issues of EESy Solutions they can be downloaded from www.fchart.com.

Thermodynamics

The text book *Thermodynamics* has been published by Cambridge University Press (www.cambridge.org/kleinandnellis). This text book is tightly integrated with EES in order to allow students to solve practical and relevant thermodynamics problems using high accuracy property data. The use of EES allows students carry out parametric studies, produce high quality plots, apply numerical integration, and optimization.

Using EES, students can easily obtain solutions to interesting practical problems that involve nonlinear and implicit sets of equations. They can easily display the results of these calculations in plots. They can conduct design studies by varying the inputs or constraints and by applying optimization methods.

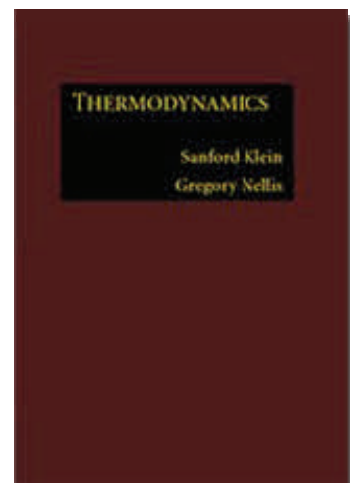

Thermodynamics

EES is a powerful tool that can be of great advantage for teaching thermodynamics and solving thermodynamics problems. However, like all tools, some training and experience are required to use it effectively. Therefore, the presentation in *Thermodynamics* teaches readers by example. Progressively more advanced features are introduced sequentially throughout the text.

Thermodynamics fills a void between theory and application in undergraduate and graduate thermodynamics education. The text was developed over many years from the experiences of the authors teaching these courses at the University of Wisconsin.

Thermodynamics together with the companion text, *Heat Transfer*, provides a means for educating tomorrow's engineer to solve complex problems in an efficient and professional manner.

“...an important new textbook

... significantly raises the bar for heat transfer text books

...a major contribution to education in the field of heat transfer

-Ralph L. Webb, Penn State University

In a review of the text *Heat Transfer* published in *Heat Transfer Education*

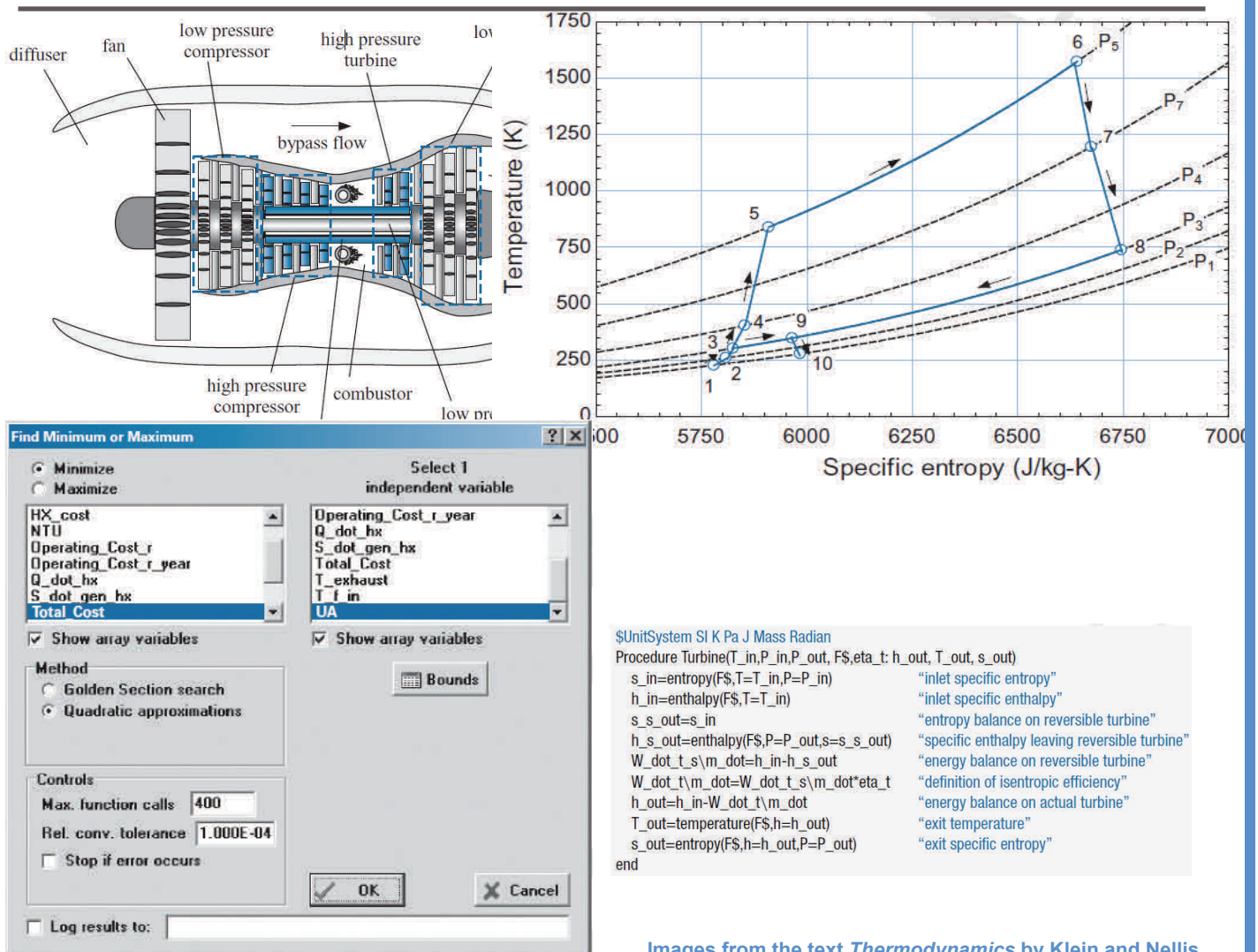

Images from the text *Thermodynamics* by Klein and Nellis

EES Training Opportunities

EES is used in many companies, organizations, and academic institutions. Most users are aware of the basic features—solving equations, Parametric Tables, plotting, and the powerful property routines. However, fewer users are aware of the more powerful features of EES such as optimization, integration, uncertainty propagation, complex algebra and subprograms. More advanced features available in the Professional version, such as the Diagram Window, animation, executables, directives, and macros can enhance the capabilities of the program and open the door to a wide range of applications.

Our staff are available to provide a 1 day EES short course tailored to new users or experienced EES users. The cost is \$1500 plus travel expenses. Contact Greg Nellis by email to arrange a training session (nellis@fchart.com).



Introduction to EES (2 hours)

This seminar is meant for people with limited or no experience using EES who want to get started with the program. The seminar will introduce some of the basic features, including:

- Entering and solving equations
- Parametric Tables
- Basic plotting
- Units
- Arrays & Lookup Tables
- Curve fitting & Interpolation
- Thermodynamic and transport properties
- Functions & procedures

Advanced Features of EES (2 hours)

This seminar is meant for people who are proficient with EES and want to use the software for complex problems. The seminar will introduce some of the advanced features of EES that are available in the Professional version, including:

- Advanced plotting options
- Advanced Diagram Window features
- Animation
- Distributables
- Directives
- Macros
- Methods for integrating EES with external programs, e.g., EXCEL, MATLAB and LabView

Additional Features of EES (2.5 hours)

This seminar is meant for people with some experience with EES who want to improve their productivity and understand the software more completely. The session will introduce additional features of EES that are available in the commercial version, including:

- Strategies for debugging & ensuring convergence
- Single & multi-variable and constrained optimization
- Numerical integration
- Modules & Subprograms
- Libraries
- Basic Diagram Window features
- Uncertainty propagation
- The Heat Transfer Library
- Complex Algebra

A sample agenda for a 1 day short course

Macro Command Enhancements

Macro commands are a set of instructions that EES can read from a text file or the Macro Window. Any of the actions that you can manually initiate in EES using the menus can be accomplished via a macro command. Macros also provide additional functionality. Macros allow a set of repetitive commands to be scripted so that they can be re-executed with a single click. Macros can be used to integrate EES programs with one another or with an external program. The macro commands have been improved substantially. Some specific additions are listed below.

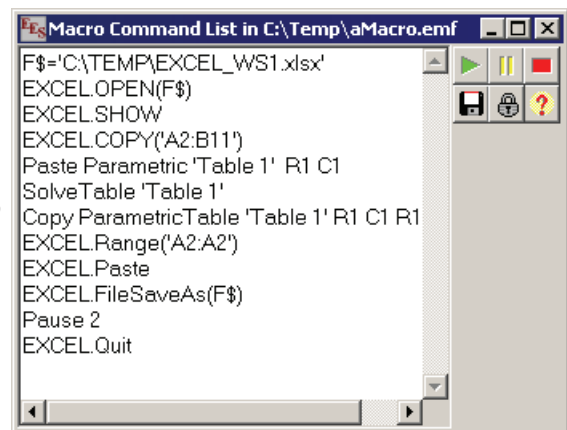

- Nested Repeat-Until constructs can be used in a macro file.
- The Stop macro command stops the execution of the macro as if the stop button were selected.
- Macros by default write a log file, EESMacro.log, that lists each command that is executed. The macro command LogFileName can be used to change the name of the log file; for example, LogFileName MyLog.log changes the file name to MyLog.log. If no name is provided then no log file is created which can be an advantage if the EES macro is running in a continuous loop while interacting with another program (as described in the article Interfacing with Excel, MATLAB, and LabView).
- The command Log Macro Off disables writing to the macro log file. Log Macro On resumes writing.
- The MinimizeTable and MaximizeTable macro commands have been implemented in the Professional version. These macro commands allow a method keyword that can specify the optimization method. The method keyword has also been added to the Minimize and Maximize macro commands.
- Macro commands that allow EES to interact with MATLAB have been added. These commands include the MATLAB.Open command which opens MATLAB, the MATLAB.Execute(Command\$) command which executes the command string Command\$ in MATLAB, and the MATLAB.Quit command which closes MATLAB.
- The LookupCollInfo macro command allows the names and units of columns in a Lookup Table to be changed.
- The Log Message\$ macro will write the message string Message\$ to the log file at the position where it is executed and therefore it can be useful for debugging.
- A series of macro commands have been added that allow EES to interact with Excel. These include:
 - Excel.Cell: places text into a specified cell
 - Excel.FileNew: starts Excel
 - Excel.FileOpen: open an Excel file
 - Excel.FileSaveAs: saves Excel file
 - Excel.Hide: hide an Excel file
 - Excel.Paste: paste the contents of the clipboard into Excel at the selection point specified by Excel.Range
 - Excel.Range: sets the selection point
 - Excel.Quit: close Excel
 - Excel.Sheet: activates an Excel sheet
 - Excel.Show: makes the current Excel worksheet visible

Controlling Excel from EES



There is a rich set of macro commands that can be used to control Excel from within an EES macro. For example, suppose that you have temperature and pressure data within Excel (as shown). You would like to use EES to fill in the remaining columns corresponding to specific enthalpy, specific entropy, and specific volume.

You can automatically copy these data, paste them into a Parametric Table, solve the table to compute h , s , and v , and copy the columns from EES back to Excel. First, create an EES program that computes the required properties and create the Parametric Table.

	A	B	C	D	E
1	T [C]	P [kPa]	h [kJ/kg]	s [kJ/kg-L]	v [m ³ /kg]
2	1.00E+02	5.00E+02			
3	1.10E+02	5.00E+02			
4	1.20E+02	5.00E+02			
5	1.30E+02	5.00E+02			
6	1.40E+02	5.00E+02			
7	1.50E+02	5.00E+02			
8	1.60E+02	5.00E+02			
9	1.70E+02	5.00E+02			
10	1.80E+02	5.00E+02			
11	1.85E+02	5.00E+02			

The screenshot shows three windows from the EES software:

- Equations Window:** Contains the unit system $\$UnitSystem SI C kJ kPa mass$ and the following equations:

```
R$='R134a'
h=enthalpy(R$,T=T,P=P)
s=entropy(R$,T=T,P=P)
v=volume(R$,T=T,P=P)
```
- Parametric Table:** Shows a table with 5 columns: T [C], P [kPa], h [kJ/kg], s [kJ/kg-K], and v [m³/kg]. The table has 10 rows labeled Run 1 through Run 10.
- Macro Command List:** A list of commands for controlling Excel, including file opening, data copying, solving the parametric table, and saving the file.

Next, select Open or Create Macro from the File menu and write the macro. The macro opens and displays the Excel file with the data. The data are copied to the clipboard and pasted into the Parametric Table which is then solved. The results in the table are copied to the clipboard and pasted into the Excel file. Finally the Excel file is saved. Run the macro and you should see that the Excel file has the columns filled in.

This approach can be expanded to post-process large amounts of data that are stored within Excel files automatically using EES. The same approach can be used to control MATLAB from EES as well as other programs.

```
File$='C:\Temp\ExcelData.xls' //name of Excel file
Excel.Open(File$) //open the Excel file
Excel.Show //make the file visible

Excel.Copy('A2:B11') //copy the temperature & pressure data to the clipboard
Paste Parametric 'Table 1' R1 C1 //paste the data into the Parametric Table

SolveTable 'Table 1' //solve the Parametric Table
Copy ParametricTable 'Table 1' R1 C3 R10 C5 //copy the results in the Parametric Table to clipboard

Excel.Range('C2:C2') //set the insertion point in the Excel document
Excel.Paste //paste the contents of the clipboard into Excel at the insertion point

Excel.FileSaveAs(File$) //save the file
Excel.Show //make the file visible
Pause 2 //pause for 2 seconds
Excel.Quit //close Excel
```

Controlling EES from MATLAB

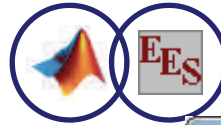

Macros also provide a method for other programs to control EES. Macros can be executed using the system command. Entering EES.exe followed by the name of macro will cause EES to open and then execute the commands listed in the macro file.

We can use this capability to allow MATLAB, Excel, LabView, etc. to control EES. For example, let's develop a simple function in MATLAB that uses EES to compute specific volume given a fluid name, temperature, and pressure. The EES program TestMacro.ees uses the internal thermodynamic property routines to accomplish the required calculations. The macro (aMacro.emf) opens the EES program and imports the parameters R\$, T, and P from the text file Input.dat. The Equations Window is solved and the parameters are written to the text file Output.dat.

Create a text file manually and save it as Input.dat with a string for the fluid and two numbers for the temperature and pressure. Use the Run dialog to execute the EES macro automatically. You should see that the file Output.dat is created with the results.

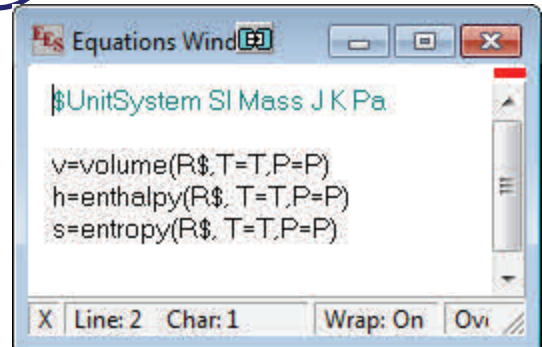

EES program TestMacro.ees

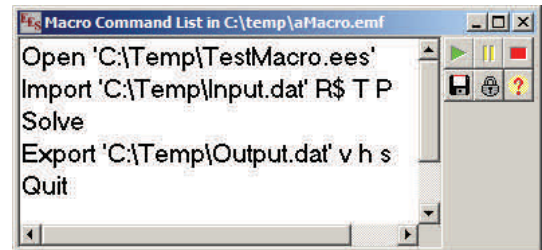

Macro file aMacro.emf

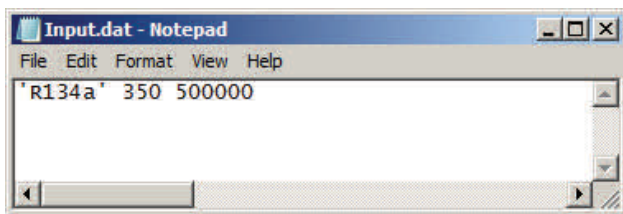

Input.dat file

You can write a MATLAB function that accomplishes the same thing. The function below takes in the fluid, temperature, and pressure, writes these parameters to the file Input.dat, executes the EES macro, and reads the results from the file Output.dat.

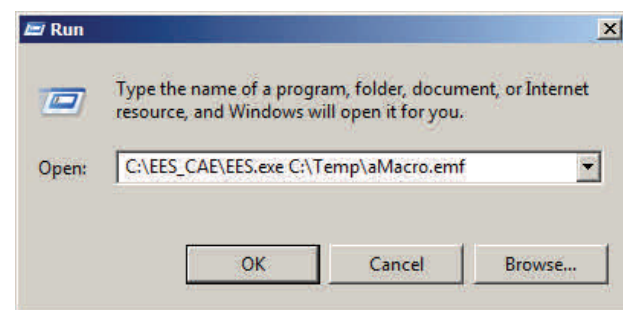

Execute the macro from the Run dialog

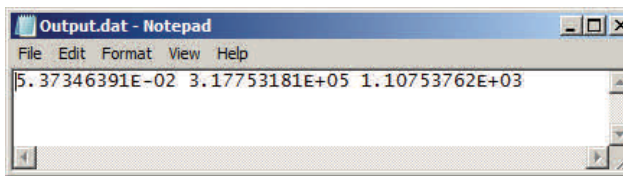

Output.dat file

This technique can be expanded to accomplish more complex tasks and it can be used with any program that can execute system commands (e.g., Excel or LabView).

```
function [h, s, v]=EESProperty(R,T,P)

    fid=fopen('C:\Temp\Input.dat','w');
    fprintf(fid,'%s' %f %f',R,T,P);
    fclose(fid);

    system('C:\EES_CAE\EES.exe C:\Temp\aMacro.emf');

    pause(5);

    vhs=importdata('C:\Temp\Output.dat');
    v=vhs(1);
    h=vhs(2);
    s=vhs(3);

end
```

MATLAB function

Controlling EES from LabView

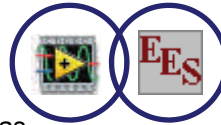

In the previous example, it was inconvenient that EES was closed and restarted each time MATLAB wanted to call the function. An alternative approach starts EES and lets it run in a continuous loop. When the timestamp on the file Input.dat changes then EES executes a series of commands that involve reading in the input parameters, solving the equations, and then writing a new file Output.dat.

This approach keeps EES open continuously but causes it to run only when needed, as signaled by writing the file Input.dat. Notice that the LogFileName command deactivates the log file which would otherwise grow continuously within the never-ending Repeat-Until loop. Also notice the use to the TimeStamp command that reads the timestamp of a file on the disk.

Start the EES macro and EES will sit and wait for a new Input.dat file to be written. Any program can activate EES by writing this file.

```

Macro Command List in C:\temp\monitorLabView.EMF
Open 'C:\Temp\TestMacro.ees'
LogFileName
Beep 1
InputFile$='C:\temp\input.dat'
OutputFile$='C:\Temp\Output.dat'
old=TimeStamp(InputFile$)
10:
  Pause 0.2
  new=TimeStamp(InputFile$)
  If (new>old) Then Goto 20
Goto 10

20:
  Beep
  Import InputFile$ R$ T P
  Solve
  Export OutputFile$ v
  old=new
Goto 10
    
```

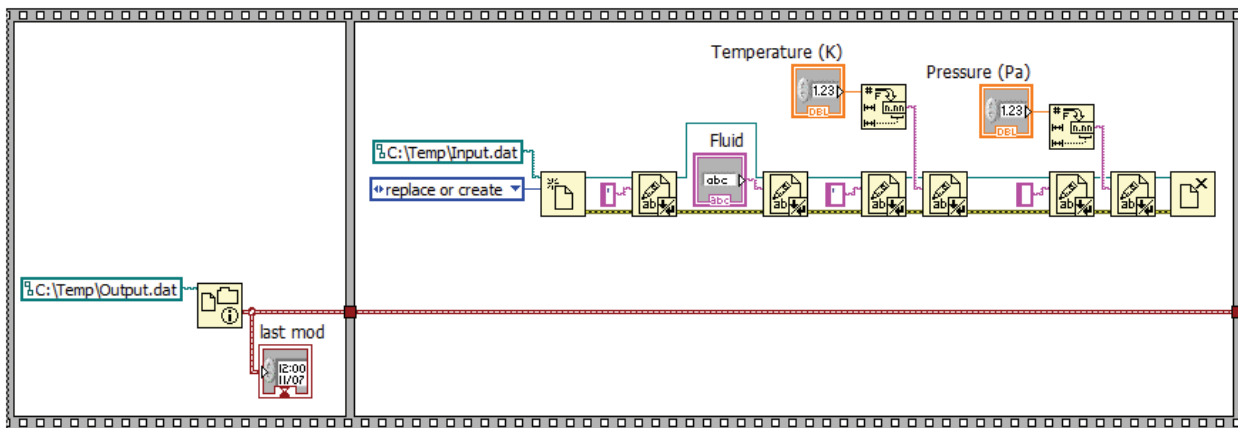

For example, this LabView vi gets the timestamp of the file Output.dat, writes the file Input.dat (using user-provided values of fluid, temperature, and pressure), and then waits until the timestamp of the file Output.dat changes at which time it reads the results of the calculation.

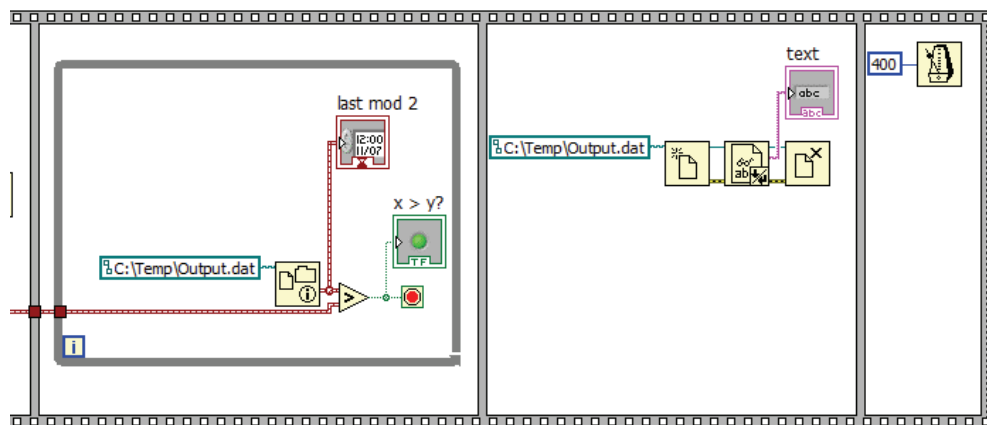

Additional Changes to EES

F-Chart Software

Box 44042
Madison, WI

Phone/FAX: 608-274-4262
Internet: <http://fchart.com>
E-mail: info@fchart.com



Foreign Language Capabilities

EES files can now be saved using names and in directories that utilize foreign language characters.

A palette of graphic items has been added to the Diagram window

The number of measured uncertainty variables that can be considered has been increased to 200

The Modify Axes dialog (Plots menu) provides an option to scale the axis values by a factor of 10.

New Fluid Properties

Properties for Siloxane_3 (MDM, octamethyltrisiloxane), dimethyl ether, and nitrous oxide have been added

Introduction to EES Videos

Videos that introduce the basic features of EES as well as the use of the thermodynamic property routines can be downloaded or executed from www.fchart.com/ees/add-ons.php (select EES Introduction or EES Properties)

Instant Update Service



EES uses a different model for updating than most other programs. Each time that there is a change in the EES program, either to correct a problem or to add a new feature, the version number is incremented by 0.001 and the latest version of EES is placed on our website. Although the program has become very robust and stable, there have been **250 new version** since the last EESy Solutions was distributed in the Spring of 2011.

Any user who has a current subscription to our Instant Update Service can download the latest version. All new licenses of EES are provided with one year of Instant Update Service. The fee to continue Instant Update Service after the first year is 20% of the current cost of the program per year. Contact F-Chart Software if you wish to re-subscribe to the Instant Update Service